

ATTUATORE ELETTRICO PER 235-236-255-256

Attuatore elettrico con connessione ISO 5211
 Gamma di torque tra 15Nm e 4300Nm
 Possibilità di sblocco manuale
 Manovra 90°, tempi tra 13 e 152 secondi
 Ingressi elettrici 2 x ISO M20
 Protezione IP68
 Conforme CE

Disponibili nelle versioni:

- Multivolt 85-260VAC e 24VDC (fino ad AQ70)
 - 220/230 VAC o 24VDC (per AQ100 e superiori)
- Adatti a corrente alternata a 50Hz o 60Hz

Comando a 3 punti

2 finecorsa regolabili (250VAC-5A o 48VDC-2,5A)
 Limitatore di coppia (per AQ250 e superiori)
 Temperatura di funzionamento: da -20° a +60°C



DATI TECNICI

Codice	Modello	Alimentazione	Torque	Potenza	Manovra
KACUTAQ00.800	AQ15	85-260VAC o 24VDC	15Nm	20W	13 sec.
KACUTAQ01.800	AQ30	85-260VAC o 24VDC	30Nm	20W	15 sec.
KACUTAQ02.800	AQ70	85-260VAC o 24VDC	70Nm	20W	15 sec.
KACUTAQ03.800	AQ100	220/230VAC	100Nm	15W	25 sec.
KACUTAQ04.800	AQ150	220/230VAC	150Nm	30W	30 sec.
KACUTAQ05.800	AQ250	220/230VAC	250Nm	40W	30 sec.
KACUTAQ06.800	AQ300	220/230VAC	300Nm	40W	35 sec.
KACUTAQ07.800	AQ500	220/230VAC	500Nm	60W	35 sec.
KACUTAQ11.800	AQ800	220/230VAC	800Nm	60W	55 sec.
KACUTAQ12.800	AQ2000	220/230VAC	2000Nm	150W	55 sec.
KACUTAQ13.800	AQ4300	220/230VAC	4300Nm	150W	152 sec.
KACUTAQ08.800	AQ100	24VDC	100Nm	30W	25 sec.
KACUTAQ09.800	AQ150	24VDC	150Nm	30W	30 sec.
KACUTAQ10.800	AQ250	24VDC	250Nm	50W	30 sec.

DIMENSIONI

Modello	Flangia	Connessione [mm]	Weight [kg]
AQ15	F03, F04, F05, F07 ¹	□9, □11, ⌀14	2,5
AQ30	F03, F04, F05, F07 ¹	□9, □11, ⌀14	2,5
AQ70	F05, F07	□11, □14, □17, ⌀22	3,0
AQ100	F05, F07	□14	10,0
AQ150	F05, F07	□14	10,0
AQ250	F07, F10	□17	15,0
AQ300	F07, F10	□17	15,0
AQ500	F07, F10	□22	15,0
AQ800	F10, F12	⌀22	18,0
AQ2000	F16	□27	48,0
AQ4300	F16	□36	58,0

¹Attraverso adattamento incluso

Adattamenti a flange e connessioni diverse da quelle indicate disponibili a richiesta

Le dimensioni indicate sui disegni sono in mm

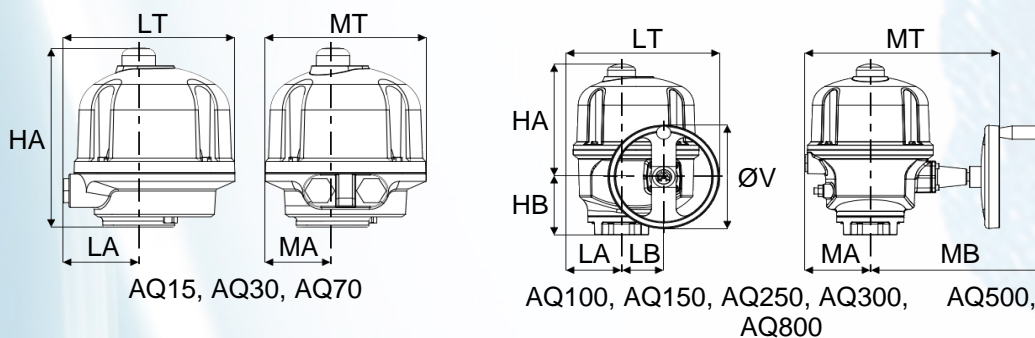

AQ15, AQ30, AQ70

AQ100, AQ150, AQ250, AQ300, AQ500, AQ800

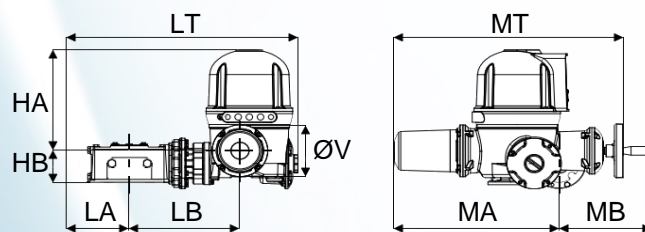

AQ2000, AQ4300

Modello	LA [mm]	LB [mm]	LT [mm]	MA [mm]	MB [mm]	MT [mm]	HA [mm]	HB [mm]	ØV [mm]
AQ15	67	-	152	60	-	143	173	-	-
AQ30	67	-	152	60	-	143	173	-	-
AQ70	67	-	153	60	-	143	191	-	-
AQ100	74	60	184	96	184	230	204	82	100
AQ150	74	60	184	96	184	230	204	82	100
AQ250	86	74	224	117	248	315	215	102	100
AQ300	86	74	240	117	310	347	217	111	160
AQ500	86	74	260	117	310	347	217	111	200
AQ800	117	75	316	131	310	361	291	149	250
AQ2000	115	307	582	360	354	634	339	75	160
AQ4300	127	350	637	256	458	634	339	75	160

SCHEMI ELETTRICI

Sigla	Definizione
OLS	Fine corsa in apertura
CLS	Fine corsa in chiusura
OXS	Fine corsa ausiliario 1
CXS	Fine corsa ausiliario 2
OTS	Int. di coppia in apertura
CTS	Int. di coppia in chiusura
M	Motore
H	Resist. Anticondensa
N	Collegamento a neutro
Ph	Collegamento a fase
T/E	Messa a terra

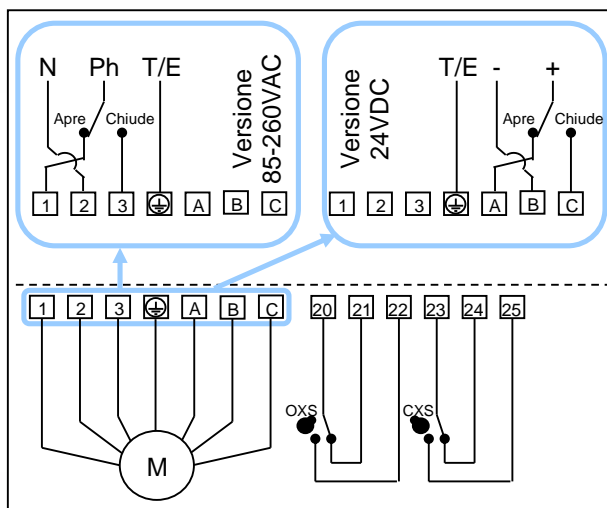

KACUTAQ00.800, KACUTAQ01.800,
KACUTAQ02.800

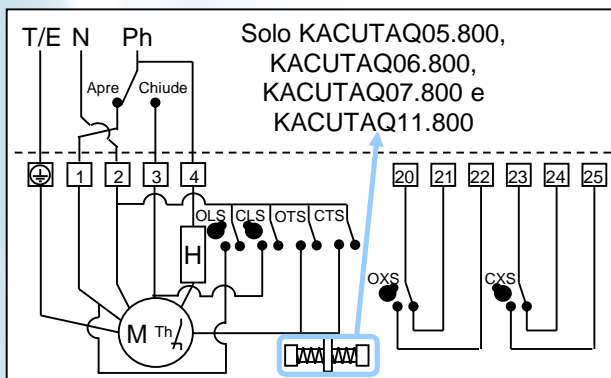

KACUTAQ03.800, KACUTAQ04.800, KACUTAQ05.800,
KACUTAQ06.800, KACUTAQ07.800, KACUTAQ11.800

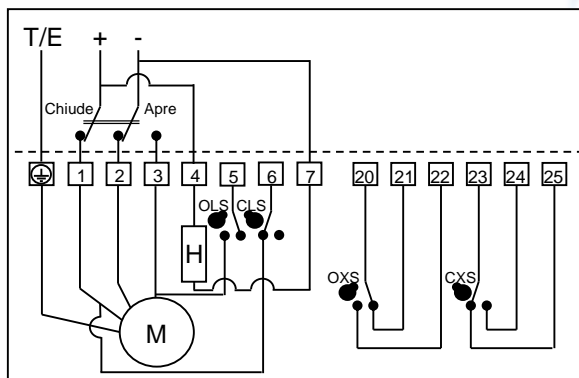

KACUTAQ08.800, KACUTAQ09.800

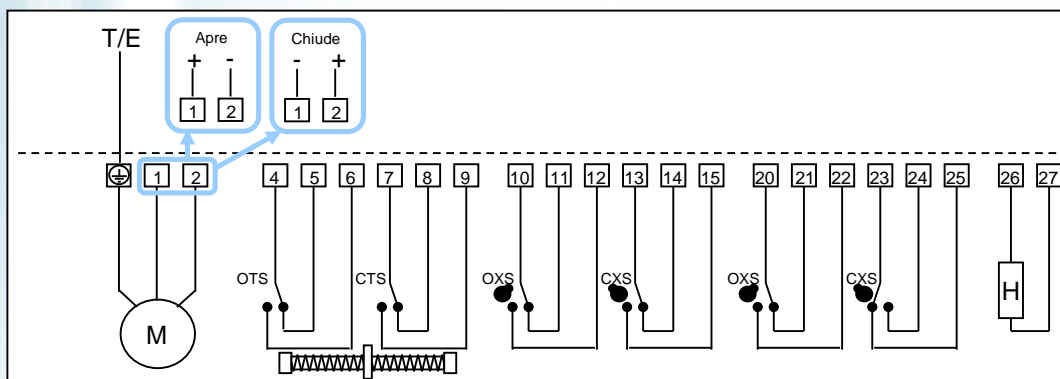

KACUTAQ10.800

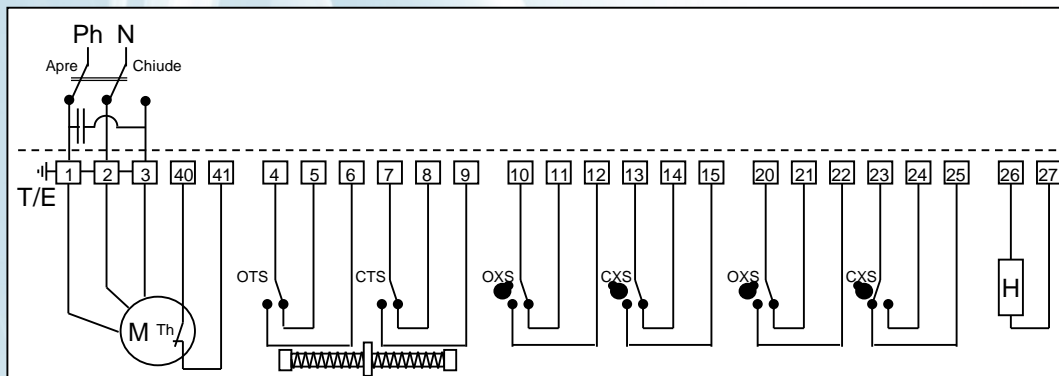

KACUTAQ12.800, KACUTAQ13.800

I disegni, le foto e i dati contenuti in questa scheda sono forniti a puro titolo informativo. Ci riserviamo il diritto di apportare ad essi variazioni senza preavviso.

